

MALM FIREPLACES, INC.



Imperial Carousel

Clearview Glass

ASSEMBLY AND INSTALLATION INSTRUCTIONS

Tested to U/L Standard 737

SAFETY NOTICE

If this fireplace is not properly installed, a house fire may result. To reduce the risk of fire, follow the installation instructions. Contact local building or fire officials about restrictions and installation inspection requirements in your area.

This stove must be connected to (1) a chimney complying with the requirements for Type HT chimneys in the Standard for Chimneys, Factory-Built, Residential Type and Building Heating Appliance, UL 103, or (2) a code-approved masonry chimney with a flue liner.

Please read this entire manual before you install and use your new fireplace. Failure to follow instructions may result in property damage, bodily injury, or even death.

DO NOT INSTALL THIS UNIT IN A MOBILE HOME.

1. Carefully remove all components from the shipping cartons and inspect for damage. If any damage is noted contact the shipping company or your dealer immediately. **DO NOT INSTALL THIS UNIT IF DAMAGED OR MISSING PARTS.**
2. Protect the flooring near the intended place of installation with an old rug, blanket, or cardboard. Place the firebox on this material.
3. Mix and install the Malmcrete hearth refractory as follows:
 - a. Obtain a sturdy water-tight mixing container such as a wheelbarrow or large wash tub, a bucket or can for transporting the mixture, a cement trowel, and a source for clean mixing water. It is suggested that the Malmcrete be mixed outside to avoid spillage or splatters in the dwelling.
 - b. Pour the dry Malmcrete mixture into the mixing container.
 - c. Use 1 quart water for each bag.
 - d. Add 1/2 to 3/4 of the water to the dry mix and mix thoroughly. Add additional water in small increments, mixing thoroughly between additions. Do not add more water than is necessary to get a somewhat dry mixture; too much water in the mix may cause the refractory to crack excessively, and will reduce the strength of the refractory. To test for proper water content, cut vertically into the mixture with the trowel, push the trowel sideways to open a 3 inch deep by 2 inch wide cut in the mixture, then slide the trowel back up out of the cut. The cut should stay open with very little "slumping" back into the cut. Next, run the trowel over the surface of the mixture with the blade at a slight angle to the surface of the mixture, like spreading butter. The mixture should become relatively smooth with few voids

after 6 or 7 passes of the trowel using moderate pressure. Water should not float to the top of the mixture.

- e. Transfer the mixture to the hearth (floor) area inside the firebox, spreading the mixture out as it is added. Use the trowel to spread the mix into the firebox area. Continue to add refractory until there is a minimum of 2 inches thick over the entire hearth area. To measure the depth of the mix, place a piece of tape 2 inches from the pointed end of a long nail. Insert the nail vertically through the mix every 6 inches (front to back and side to side) across the hearth; the mix should come to a uniform height up the nail, at or slightly above the tape.

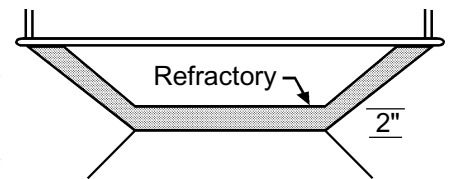

- Trowel in the nail holes when completed. Shape the refractory to the contour of the Imperial hearth. If the refractory will not stay in place wait until the refractory has set slightly. Check the refractory every few minutes to see if it has set enough to stay in place.
- f. Allow the mix to cure at least 48 hours. Additional curing time is necessary in cool temperatures. The longer Malmcrete is allowed to cure before the first fire is lit, the stronger and more durable it will become.
 - g. Make the first 3 or 4 fires very small and of short duration to allow the refractory to adjust to the high temperature of a fire.

Glass Installation

Wear eye protection during the assembly of this unit. Check all glass and parts for damage. Replace any damaged parts prior to continuing the installation. Do not assemble this unit with any damaged parts. If you should happen to break a glass panel, it must only be replaced with ceramic glass.

1. The door panel has had the latch assembly and hinges installed at the factory. Remove the hinges leaving the glued on plate in position.
2. Place the lower hinge in the hole in the firebowl, with the washer under it.
3. Insert the upper hinge into the hole at the top of the door opening. Holding the upper hinge in place, slide the glass door panel into the hinges.
4. Hold the door panel in the closed position to allow access to the hinge screws.
5. Maintaining a 1/8" clearance to the left door post, tighten the screws in the hinges snugly. **DO NOT OVER TIGHTEN.** Re-adjust as necessary for proper alignment.
6. Note that two panels have gasket material on one edge. These pieces go on either side of the door. Make certain that these two pieces are placed completely into the channel on either side of the door. Failure to do this will make the rest of the glass installation impossible.
7. First loosen the glass retainers. This is a metal strip secured by one screw in the middle. Start with the left door panel. The gasket must be on the right side of the panel.

8. Slide the gasketed edge completely into the channel on the side of the door. The left edge of the glass should now fit into the button at the bottom of the glass.
9. Lower the glass into the lower glass button channel.
10. Repeat steps 8 and 9 with the right door panel. The gasket will be on the left side of the panel with the not polished edge at the top.
11. The remaining panels can now be installed. The edge that is not polished is placed at the top. As each panel is installed replace the glass retainer in place but do not tighten.
12. After all the glass panels are installed center the panels to reduce any gaps that may be between the glass panels.
13. Tighten the glass retainers.

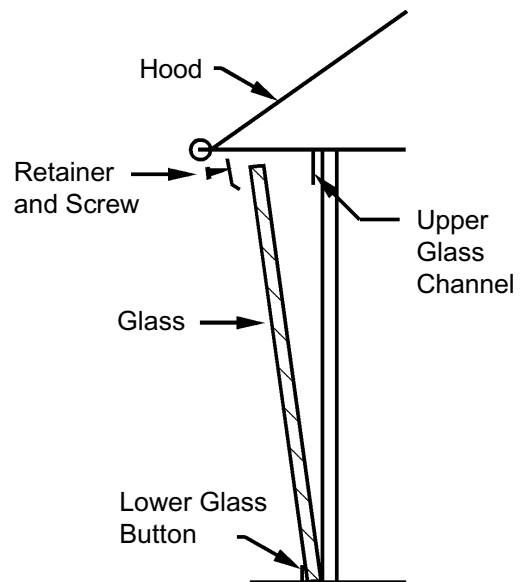

Clearance to Combustibles

The Imperial requires a clearance to combustible walls of 42" measured from the back of the unit. For locating the center of the chimney the measurement is 63" from the backwall and 63" to the sidewall. See figure 1, page 2. For corner installation the center of the chimney is 63". See figure 2, page 2.

Clearance to Non-combustibles

The Imperial clearance to a combustible wall may be reduced with proper wall protection. Accepted methods for wall protection would allow reduction of the wall clearances. For appearance if desired a non-combustible wall covering can be placed on the wall. The covering should consist of a listed wall protection board installed to the manufacturer's specifications. Approved protection boards at the time of this publication are Wonderboard, Dura Rock and Homosote. A non-combustible material can then be placed over the wall protection board. With most of the protection boards the clearance can be reduced by 2/3 from the original combustible wall. Be certain to check with your local building officials and or fire inspector for accepted methods in your area.

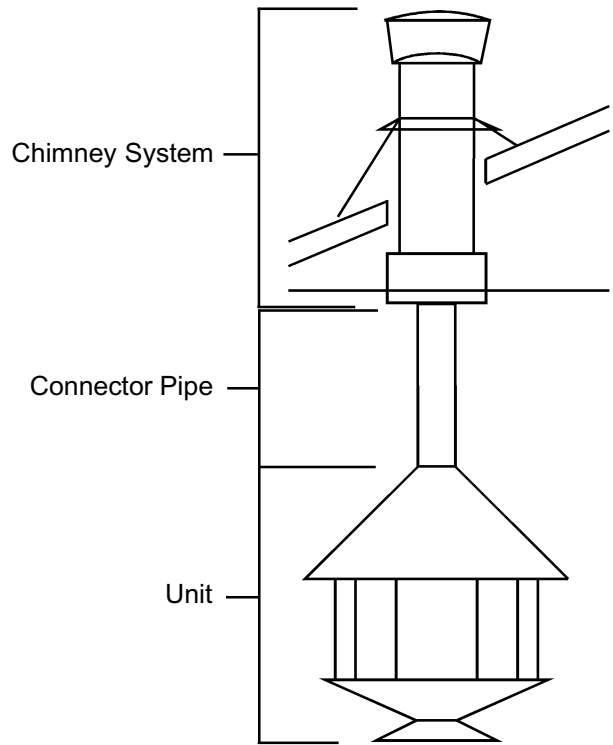

SIDEWALL AND BACKWALL INSTALLATION

Unit to Sidewall -----	42"
Unit to Backwall -----	42"
Connector to Sidewall -----	58"
Center of Connector to Sidewall -----	63"
Connector to Backwall -----	58"
Center of connector to Backwall -----	63"

CORNER INSTALLATION

Unit to Adjacent Wall -----	42"
Connector to Adjacent Wall -----	58"
Center of Connector to Adjacent Wall -----	63"
Minimum Hearth Size -----	48" x 54"
Or a Diameter of -----	54"

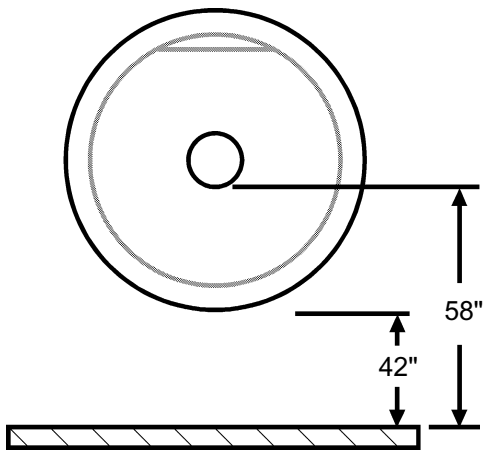

Figure 1.

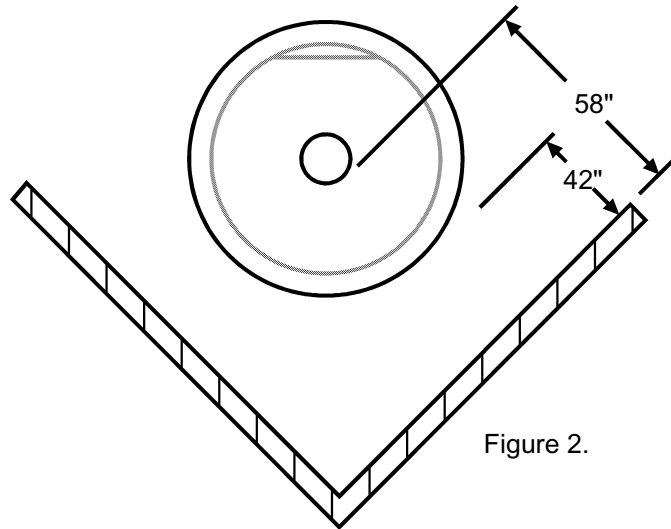

Figure 2.

Hearth dimensions shown are minimum requirements. It may be desired to exceed these minimum dimensions for a more decorative installation.

Hearth Requirements

A floor protector is required to protect the floor in front of the fireplace opening from sparks. The floor protector must be a minimum of 2 1/2 inch thick common solid brick over 26 gauge sheet metal or equivalent.

The floor protector must extend a minimum of 16 inches in front of the fireplace opening and 8 inches to either side of the fireplace and 8 inches behind the back of the unit. Refer to Figure #3.

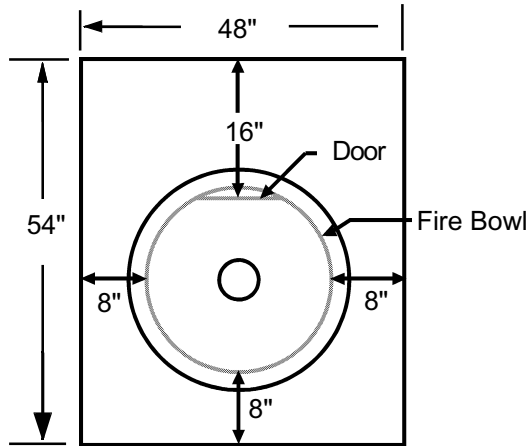
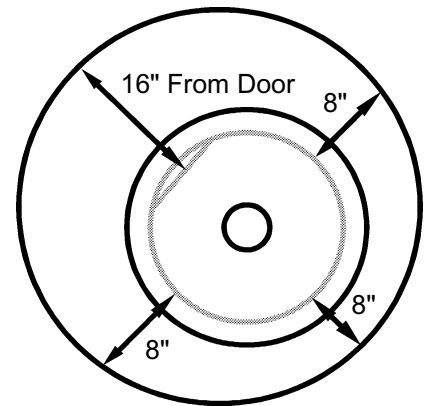

Figure 3



54" Diameter Circle Hearth.
8" Minimum is measured from the fire-box

Hood Assembly

Position the hood on the basic unit. Secure hood to basic unit using the 13 sheet metal screws provided.

IMPORTANT: Failure to install these screws will result in permanent damage to the unit and void the warranty.

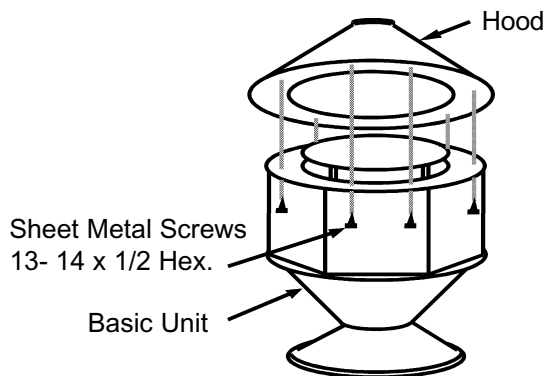

All Screws Must Be Installed

Simpson Dura-Vent Chimney System

It is required to use a Dura-Vent Universal Connector part number 8874 to install the chimney connector.

1. The universal connector is installed into the support box. The 8" x 30" slip pipe is then connected to the universal connector.
2. The 8" x 30" starter pipe section is then slid over the slip connector pipe. Slide the 30 inch pipe over the slip pipe only far enough as necessary to facilitate installation of the 8" x 30" starter pipe in to the unit.
3. There must be a minimum of 2 inches of overlap between the 8" x 30" and 8" x 30" slip connector pipe.

Metalbestos or Security

When using Metalbestos or Security chimney systems it is required to use the Metalbestos DS-CPA Single Wall Conector pipe. Security users must use the UP adapter.

1. Installation of the Metalbestos DS-CPA or the Security UP adapter must be done first.
2. Attach the 8" x 30" slip connector to the DS-CPA or UP adapter with 3 - #8 x 3/8 inch screws.
3. The 8" x 30" starter pipe section is then slid into the slip connector pipe. Slide the 30 inch pipe into the slip pipe only far enough as necessary to facilitate installation of the 8" x 30" starter pipe into the unit.
4. Slide the 8" x 30" pipe down onto the Imperial.
5. There must be a minimum of 2 inches of overlap between the 8" x 30" and 8" x 30" slip connector pipe.

Other Chimney Systems

There are many other manufacturer's of chimney systems. It is beyond the scope of this publication to cover installation with all of the different systems available. Most systems have a method of connection to the Imperial's connector pipe. Confirm installation procedures with your dealer or the manufacturer of the chimney system you have purchased.

DO NOT CONNECT THIS UNIT TO A CHIMNEY FLUE SERVING ANOTHER APPLIANCE.

This stove must be connected to (1) a chimney complying with the requirements for Type HT chimneys in the Standard for Chimneys, Factory-Built, Residential Type and Building Heating Appliance, UL 103, or (2) a code-approved masonry chimney with a flue liner.

Chimney Connector Installation

It is required to install a 8 inch all-fuel class "A" chimney system prior to the chimney connector installation. The connector pipe included with the Imperial is 1 - 8" x 30" starter pipe, and 1 - 8" x 30" slip connector. The slip connector is identified by 3 holes at the top of the pipe. The slip connector has one flair at the top with the 3 holes. The bottom is smooth. The starter pipe section has flairings at both ends. The male end is always at the bottom.

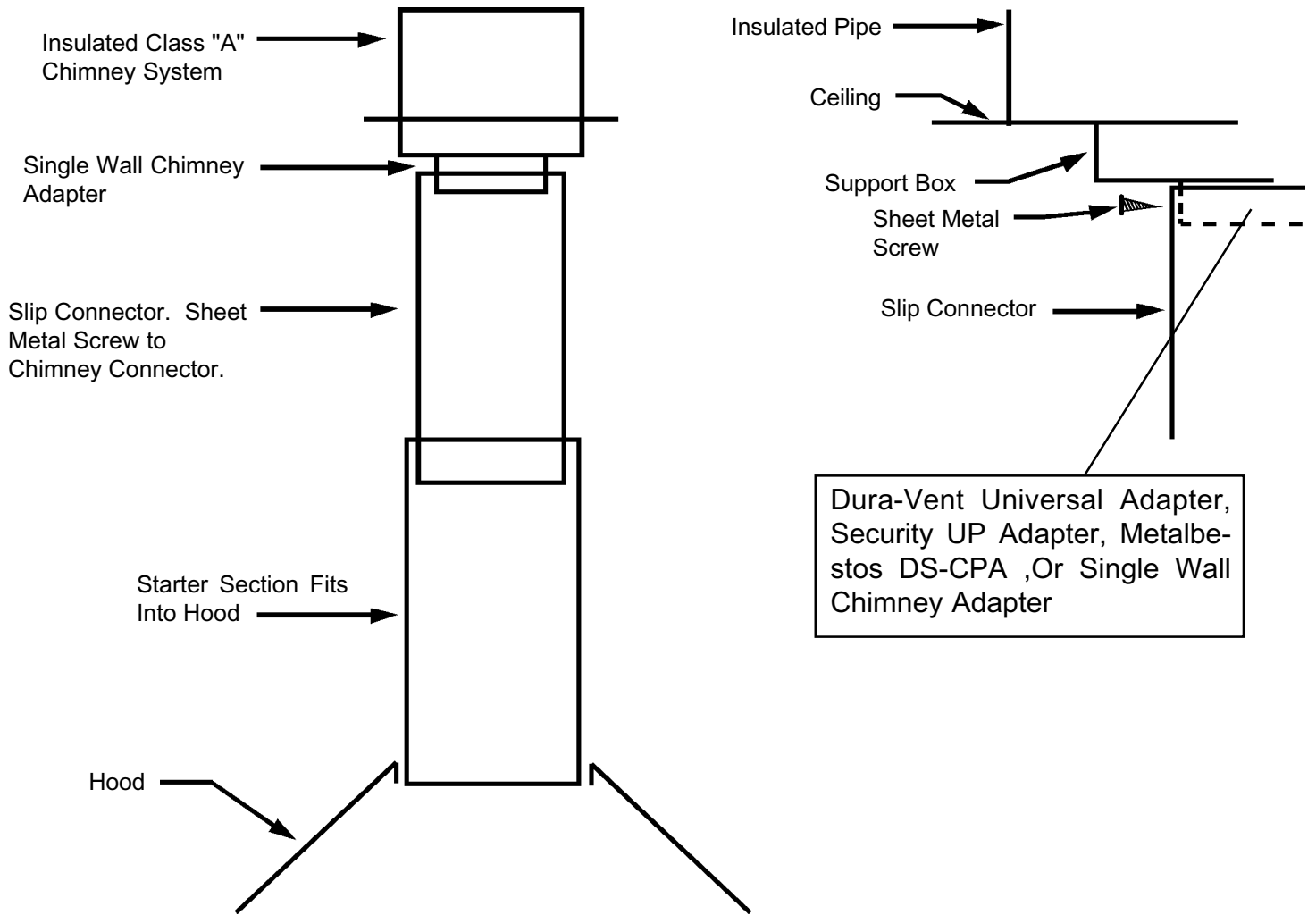

The above illustration represents the installation procedure for dripless pipe installation. This installation method of installing the connector pipe with the male end down allows for any moisture to remain on the inside of the connector pipe.

IMPORTANT: THE SINGLE WALL CONNECTOR PIPE MUST NEVER PASS THROUGH A COMBUSTIBLE CEILING OR WALL.

At first glance you may become concerned that smoke will escape the pipe and enter the room. This is not how the system will work. The vacuum in the chimney system will always pull air into the chimney. If you experience a downdraft with your installation it indicates that additional chimney height or a specialty draft cap be added to your chimney system. Contact your dealer for further information regarding downdrafts.

Masonry Chimney

If using a masonry chimney, it must meet the minimum standards of the National Fire Protection Association (NFPA) Standard 211. The chimney must have at least a 5/8" fire clay liner or a listed chimney liner system. The chimney must be inspected for cracks, loose mortar, or any other signs of deterioration. It is best to have the chimney inspected by a professional. Make certain the chimney is cleaned prior to installation of this fireplace.

The size of the chimney should be between 36 and 96 square inches. Larger chimneys should be relined to meet these requirements. Incorrect sizing of the chimney may affect the draft and result in poor fireplace performance. Do not install more than one appliance to any chimney.

There are different accepted methods of connecting the fireplace to a masonry chimney through a combustible wall. This type of installation requires the use of a thimble to protect the surrounding combustible materials. Check with your local building officials or consult NFPA211.

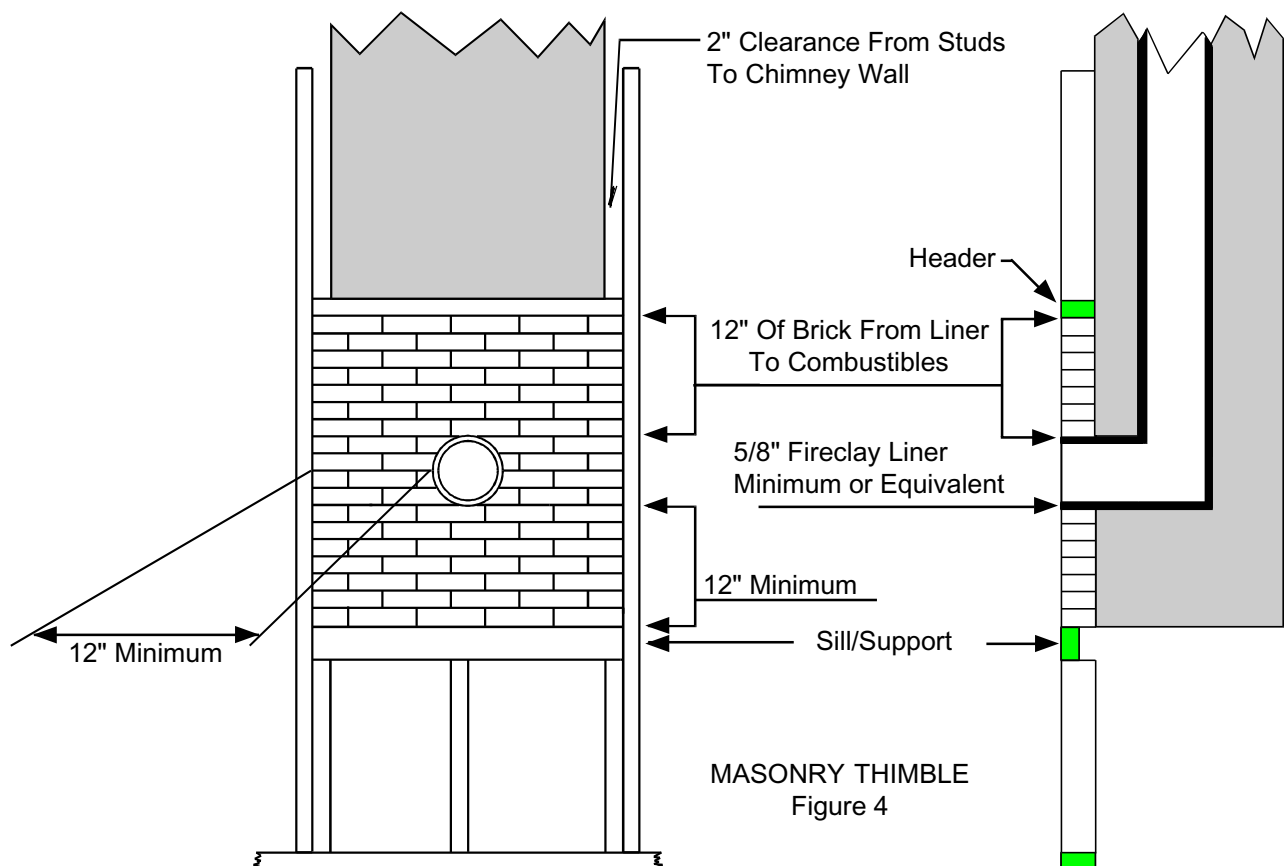

OPERATING INSTRUCTIONS

Failure to properly use and maintain this appliance may void the manufacturer's warranty and could result in a house fire.

WARNING: This free standing fireplace is a heat producing appliance and may cause severe burns if touched. Keep children away. Do Not over fire. If any portion of the unit or flue starts to glow you are over firing. This is a free standing fireplace, do not use for any other purpose.

1. The first few fires should be small in order to properly cure the painted surfaces and refractory. During the first few fires, some smoking may occur as the paint cures. You may wish to open a window to minimize discomfort during this curing period.
2. **DO NOT BURN TRASH OR GARBAGE IN THIS UNIT.** When building a fire, be sure the damper is fully opened and sufficient combustion air is available. Place dry kindling on dry wadded paper then ignite with a match. Add progressively larger pieces of wood until the fire is well established. Leave the damper fully open. Close only after the fire has burned out completely. Add additional firewood as needed to maintain the fire.
3. The fire screen must be in place during operations. THIS FIREPLACE STOVE HAS NOT BEEN TESTED FOR USE WITH DOORS. TO REDUCE THE RISK OF FIRE OR INJURY, DO NOT INSTALL DOORS.
4. **DO NOT ELEVATE THE FIRE.** A grate should not be used.
5. **CAUTION:** Heating the air in a closed building decreases the relative humidity of the air, which will dry wood and other combustible materials. This drying lowers the ignition temperature of these materials thus increasing fire hazards. To reduce the risk of fire, some provision should be made for replenishing moisture to the air whenever a structure is being heated for extended periods.
6. Be sure to provide combustion air into the dwelling when using this or any other wood burning appliance. A partially open window or outside air register in the vicinity of the unit would be acceptable. Combustion air must be supplied in conformance with the Uniform Mechanical Code.

7. **CAUTION: NEVER USE GASOLINE, GASOLINE TYPE LANTERN FUEL, KEROSENE, CHARCOAL LIGHTER FLUID, OR SIMILAR LIQUIDS TO START OR "FRESHEN UP" A FIRE IN THIS HEATER. KEEP ALL SUCH LIQUIDS WELL AWAY FROM THE HEATER WHILE IN USE.**
8. **DISPOSAL OF ASHES:** Ashes should be placed in a metal container with a tight fitting lid. The closed container of ashes should be placed on a noncombustible floor or on the ground, away from all combustible materials, pending final disposal. The ashes should be retained in the closed container until all cinders have thoroughly cooled.
9. **READ MAINTENANCE INSTRUCTIONS.**

IN CASE OF A CHIMNEY FIRE

A safe and correct installation and extra care will help prevent a fire, but accept the idea that there could be a fire. Be prepared to handle it. Make certain everyone in the house is familiar with the warning signs of a chimney fire:

1. Call the Fire Department immediately, before doing anything else.
2. Discharge a dry chemical extinguisher into the fireplace opening. If an extinguisher is not available, toss baking soda into the opening. Do not pour water on the fire.
3. Close all air intakes to the firebox and leave closed until the fireplace, stove or stove pipe is completely cooled.
4. Watch for sparks on the roof. If necessary, hose down the roof around the chimney.
DO NOT pour water down or on the chimney.
5. After the fire is completely out, inspect the chimney for any signs of damage. If you are not certain, have your local Fire Department inspect the chimney for you. Never use a flammable liquid to kindle or rekindle a fire.
6. Never use coal in a fireplace. Coal should be used only in stoves especially designed to burn coal. If the toxic gases produced enter the room they can be fatal.

MAINTENANCE INSTRUCTIONS

Failure to properly use and maintain this appliance may void the manufacturer's warranty and could result in a house fire.

1. Always keep the area around the unit clean and clear of furniture and other objects. Keep all furniture a minimum of 48 inches away from the heater.
2. Periodically the entire unit, chimney connector, and chimney system must be inspected for leaks, broken or malfunctioning parts, and loose connections. If any problems are noted, contact your dealer for repair services. Do not operate the unit until repairs have been completed.

CREOSOTE FORMATION AND THE NEED FOR REMOVAL.

When wood is burned slowly, it produces tar and other vapors, which combine with moisture to form creosote. Creosote vapors condense in the relatively cool chimney flue, and creosote residue accumulates on the flue lining. When ignited, this creosote can make an extremely hot fire. The chimney connector and chimney should be inspected at least twice monthly during the heating season to determine if creosote buildup has occurred. If creosote has accumulated, it should be removed to reduce the chance of a chimney fire.

HOW TO REMOVE CREOSOTE.

1. Clean the chimney with brushes and equipment available at local fireplace shops.

2. Chemical chimney cleaners are used by adding them to the fire, but they are not intended for use in chimneys already containing heavy soot deposits. Rather, they are intended to inhibit soot buildup. They can be used in metal chimneys provided the manufacturers instructions are strictly followed. Generally these commercial cleaners are quite effective.
3. Call a professional chimney sweep in your area. They possess the experience and tools necessary to make the task easy.

Maintenance other than the items specifically mentioned herein are to be performed by a qualified serviceman only. Contact your dealer. For further information on using your heater safely, obtain a copy of the National Fire Protection Association publication "Using Coal and Wood Stoves Safely," NFPA HS-10-1978. The address of the NFPA is Batterymarch Park, Quincy, MA 02269. File these instructions for future reference.

NEVER STORE OR ALLOW PAPERS, KINDLING, FIREWOOD OR ANY OTHER COMBUSTIBLES WITHIN 48 INCHES OF UNIT.

MALM FIREPLACES, Inc.

368 YOLANDA AVENUE
SANTA ROSA, CALIFORNIA 95404
(707) 523-7755
FAX: (707) 571-8036
info@malmfireplaces.com

June 1992

